



川源(中国)机械有限公司  
GSD (China) Co., Ltd.

# GRB

## 三叶罗茨鼓风机

GRB three-lobe roots blower



# GRB三叶罗茨鼓风机

## GRB three-lobe roots blower

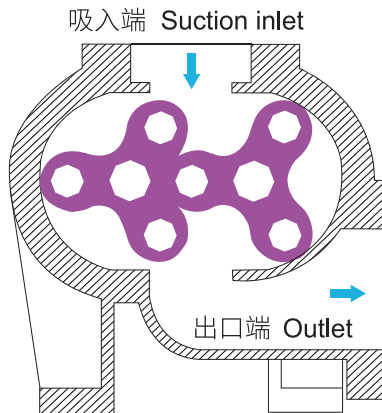

### 原理 Theory

GRB三叶罗茨风机是一种容积式风机，其压力可根据用户的要求在允许的范围内加以调节，在机壳内部设置有两组互相相反方向回轮的叶轮，在叶轮与叶轮，及叶轮与壳体间仅留极小缝隙的状态下回转。当叶轮经过吸入端时，与壳体之间捕捉一定量的空气，随叶轮转旋，空气侧移，压力逐渐升高再送至出口端。

GRB is a displacement blower, the pressure can be adjusted according to the requirement of the user in allowing range, there are two impellers in the blower body which rotate in the opposite direction, in order to let the impeller rotate, there are some tiny gap between the impeller to body, impeller to impeller. When the impeller rotates through the suction inlet, it can gather an amount of air between the body and impeller, then the impeller go on rotating, and the air will be pressured, the pressure in the body will rise, finally the air has been send to the outlet.

### 特点 Features

- 风量和压力范围大。
    - 口径：32mm-400mm (1.25 "-16")
    - 风量：0.38-283m<sup>3</sup>/min (13-9985CFM)
    - 压力：一段式GRB型可达8000mmAq (0.8kgf/cm<sup>2</sup>)
  - 排出气体不含油污。
  - 电脑动平衡校正，低振动低噪音。
  - 风量稳定，压力变化对风量之影响小。
  - 特殊叶轮设计，高效率省能源。
  - 构造简单坚固，无故障。
  - 齿轮达到5级加工精度，寿命长，低噪音。
  - 严格品质管理，标准化制品。
  - 叶轮采用龙门刨床六轴加工法，无需重复定位装夹，一次精加工完成，使更换方便，其具有更高之精密度。
- 
- Wide range of capacity and pressure.
    - Calibre: 32mm-400mm (1.25 "-16")
    - Capacity: 0.38-283m<sup>3</sup>/min (13-9985CFM)
    - Pressure: The pressure of one-stage GRB type up to 8000mmAq (0.8kgf/cm<sup>2</sup>)
  - Delivers completely oil-free air.
  - Low oscillation and low noise by dynamic balance which revised by computer.
  - Smaller change in capacity against change in pressure.
  - High efficiency due to special impeller design, great air-delivery low power.
  - Simpler and solider structure, less trouble.
  - Highest quality pilot & accurate great applied, long life and low noise assured.
  - Standardized product with strict quality control.
  - Our rotor has used the most advanced technic, one time for all working process of the six-shaft method, to enhance the precision.



## 外形结构图 Externality construction

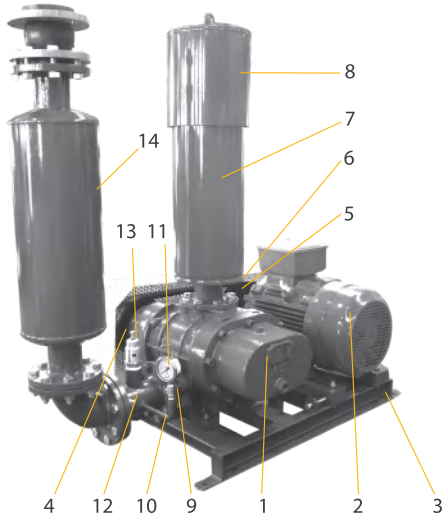

No.	名称	Name
1	本机体	Blower body
2	电动机	Motor
3	底座	Foundation
4	皮带轮	Pulley
5	传动皮带	Driving belt
6	皮带护罩	Belt cover
7	入口消音器	Suction silencer
8	防雨盖	Rain cover
9	逆止阀	Check valve
10	缓冲管	Gauge Pipe
11	吐出压力表	Outlet pressure gauge
12	三通管	T-joint
13	泄压阀	Relief valve
14	出口消音器	Outlet silencer

注：GRB-32、GRB-40 机型不配出口消音器  
 Note: GRB-32\GRB-40 without outlet silencer

## 型号说明 Type description

GRB 65

口径 (mm)      Diameter (mm)  
 三叶罗茨风机      Three-lobe roots blower

## 结构简图 Construction

No.	名称	Name	材质 Material	
			GB	JIS
1	鼓风机本体	Casing	HT250	FC250
2	轴承座	Bearing housing	HT250	FC250
3	油箱	Oil box	HT250	FC250
4	甩油片	Oil splash	Q235	SS400
5	轴承固定片	Bearing washer	Q235	SS400
6	骨架油封	Framework oil seal	NBR	NBR
7	皮带轮	Pulley	HT250	FC250
8	主动叶轮	Drive rotor	HT250	FC250
9	被动叶轮	Driven rotor	HT250	FC250
10	V型油封	V-ring	VITON	VITON
11	轴承	Bearing	GCr15	SUJ2
12	齿轮	Gear	20CrMnTi	20CrMnTi
13	止动垫圈	Lock washer	Q235	SS400
14	止动螺母	Lock nut	45	S45C
15	齿轮箱	Gear box	HT250	FC250
16	加油柱塞	Lubrication plug	45	S45C
17	润滑油面计	Oil gauge	Assembly	Assembly
18	泄油柱塞	Purge plug	45	S45C

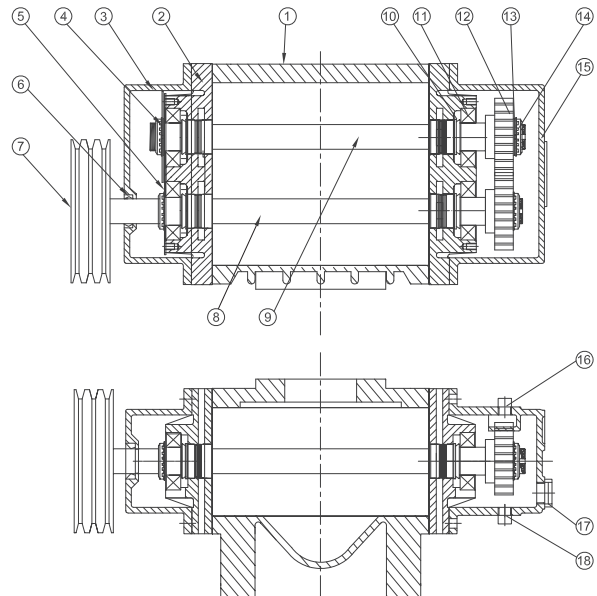

注：不同机型结构略有不同。  
 Note: Different model has a little difference.



## 单位换算表 Conversion table

PRESSURE	atm	kPa	bar	lbt/in <sup>2</sup> (psi)	kgf/cm <sup>2</sup>	in Hg	ftAq	mmHg(Torr)	mmAq
1 atm	1	101.325	1.01325	14.696	1.0333	29.921	33.914	760	10333
1 kPa	0.0099	1	0.01	0.145	0.0102	0.295	0.335	7.5	102
1 bar	0.9869	100	1	14.504	1.0198	29.53	33.47	750	10198
1 lbt/in <sup>2</sup> (psi)	0.068	6.894	0.0689	1	0.0703	2.036	2.308	51.71	703
1 kgf/cm <sup>2</sup>	0.968	98.062	0.981	14.228	1	28.96	32.82	735.53	10000
1 inHg	0.0334	3.3863	0.0339	0.491	0.0345	1	1.133	25.4	345.3
1 ftAq	0.0295	2.99	0.0299	0.434	0.0305	0.882	1	22.42	304.8
1 mmHg(Torr)	0.013	0.1338	0.00138	0.019	0.0014	0.04	0.045	1	13.6
1 mmAq	0.000097	0.0098	0.000098	0.0014	0.0001	0.003	0.0033	0.074	1

CAPACITY	m <sup>3</sup> /min	l/min	cm <sup>3</sup> /s	in <sup>3</sup> /s	ft <sup>3</sup> /min(cfm)
1 m <sup>3</sup> /min	1	1000	16667	1016	35.288
1 l/min	0.001	1	16.67	1.02	0.0353
1 cm <sup>3</sup> /s	0.00006	0.06	1	0.061	0.002
1 in <sup>3</sup> /s	0.00098	0.983	16.39	1	0.035
1 ft <sup>3</sup> /min(cfm)	0.028	28.32	471.95	28.8	1

### 压力常用换算公式

#### Pressure Conversion Formula

$$1 \text{ kPa} = 1000 \text{ Pa} = 1000 \text{ N/m}^2$$

$$1 \text{ mbar} = 10.198 \text{ mmAq}$$

$$1 \text{ mmHg(Torr)} = 133.8 \text{ Pa}$$

## 性能表使用须知 Working directions of performance table

1. 性能参数表示鼓风机之型式、口径、回转数、吐出压力、实际进口风量、轴动力。
2. 性能参数为标准吸入状态之空气量(温度20°C, 绝对压力1.0332kgf/cm<sup>2</sup>, 相对湿度65%)。
3. 基准状态(温度0°C, 绝对压力1.0332kgf/cm<sup>2</sup>)的风量, 一般以Nm<sup>3</sup>/min表示。
4. 不同状态进口风量的换算:

$$Q_2 = Q_1 \times \frac{P_1}{P_2} \times \frac{273+T_2}{273+T_1}$$

Q<sub>1</sub>: 绝对压力P<sub>1</sub>(mmAq) 摄氏温度T<sub>1</sub>(°C)状态的  
风量 (m<sup>3</sup>/min)

Q<sub>2</sub>: 绝对压力P<sub>2</sub>(mmAq) 摄氏温度T<sub>2</sub>(°C)状态的  
风量 (m<sup>3</sup>/min)

5. 电机功率一般为轴功率的1.1~1.3倍。
6. 性能参数误差约5%。

1. The performance parameter indicate the type, caliber, revolutions, discharge pressure, actual inlet air capacity and shaft power of the blower.
2. The performance parameter indicate the air quantity in standard suction condition (20°C temperature, absolute pressure 1.0332 kgf/cm<sup>2</sup> and relative humidity 65%) .
3. The reference air capacity (0°C temperature and absolute pressure 1.0332kgf/cm<sup>2</sup>) is generally indicated in Nm<sup>3</sup>/min.
4. The inlet air capacity can be converted as following.

$$Q_2 = Q_1 \times \frac{P_1}{P_2} \times \frac{273+T_2}{273+T_1}$$

Q<sub>1</sub>: Air capacity (m<sup>3</sup>/min) based on absolute pressure  
P<sub>1</sub>(mmAq) and temperature T<sub>1</sub>(°C)

Q<sub>2</sub>: Air capacity (m<sup>3</sup>/min) based on absolute pressure  
P<sub>2</sub>(mmAq) and temperature T<sub>2</sub>(°C)

5. The motor power is 1.1~1.3 multiple of shaft power.
6. The error of the parameter is about 5%.



## 性能参数 Performance parameters

Qs(m<sup>3</sup>/min) Pressure(mmAq) La(kW)

型号 Type	转速 RPM	1000mmAq		2000mmAq		3000mmAq		4000mmAq		5000mmAq		6000mmAq		7000mmAq		8000mmAq	
		Qs	La	Qs	La	Qs	La	Qs	La	Qs	La	Qs	La	Qs	La	Qs	La
GRB32	1500	0.56	0.17	0.51	0.28	0.47	0.40	0.43	0.51	0.40	0.62	0.38	0.73	-	-	-	-
	1750	0.68	0.20	0.62	0.33	0.58	0.46	0.55	0.59	0.52	0.72	0.49	0.86	-	-	-	-
	2000	0.79	0.23	0.74	0.38	0.70	0.53	0.66	0.68	0.63	0.83	0.61	0.98	-	-	-	-
	2300	0.93	0.26	0.88	0.43	0.84	0.61	0.80	0.78	0.77	0.95	0.74	1.13	-	-	-	-
	2600	1.07	0.29	1.02	0.49	0.97	0.68	0.94	0.88	0.91	1.08	0.88	1.27	-	-	-	-
	3000	1.25	0.34	1.20	0.56	1.16	0.79	1.12	1.02	1.09	1.24	1.07	1.47	-	-	-	-
GRB40	850	1.02	0.42	0.89	0.64	0.79	0.85	0.71	1.07	0.63	1.29	-	-	-	-	-	-
	950	1.18	0.47	1.05	0.71	0.95	0.95	0.86	1.20	0.79	1.44	-	-	-	-	-	-
	1050	1.33	0.52	1.20	0.79	1.10	1.06	1.02	1.32	0.94	1.59	-	-	-	-	-	-
	1150	1.49	0.57	1.36	0.86	1.26	1.16	1.18	1.45	1.10	1.74	-	-	-	-	-	-
	1250	1.65	0.62	1.52	0.94	1.42	1.26	1.33	1.58	1.26	1.90	1.19	2.22	1.13	2.54	1.07	2.86
	1350	1.80	0.67	1.67	1.01	1.57	1.36	1.49	1.70	1.42	2.05	1.35	2.39	1.29	2.74	1.23	3.08
	1450	1.96	0.71	1.83	1.09	1.73	1.46	1.65	1.83	1.57	2.20	1.50	2.57	1.44	2.94	1.39	3.31
	1550	2.12	0.76	1.99	1.16	1.89	1.56	1.80	1.95	1.73	2.35	1.66	2.75	1.60	3.15	1.54	3.54
	1650	2.27	0.81	2.14	1.24	2.04	1.66	1.96	2.08	1.89	2.50	1.82	2.93	1.76	3.35	1.70	3.77
	1750	2.43	0.86	2.30	1.31	2.20	1.76	2.12	2.21	2.04	2.65	1.98	3.10	1.91	3.55	1.86	4.00
GRB50	850	1.81	0.61	1.64	0.97	1.52	1.34	1.41	1.70	1.31	2.06	1.22	2.42	1.14	2.79	1.07	3.15
	950	2.07	0.68	1.91	1.09	1.78	1.49	1.67	1.90	1.57	2.30	1.48	2.71	1.40	3.11	1.33	3.52
	1050	2.34	0.75	2.17	1.20	2.04	1.65	1.93	2.10	1.83	2.55	1.75	2.99	1.67	3.44	1.59	3.89
	1150	2.60	0.82	2.43	1.32	2.30	1.81	2.19	2.30	2.09	2.79	2.01	3.28	1.93	3.77	1.85	4.26
	1250	2.86	0.90	2.69	1.43	2.56	1.96	2.45	2.50	2.35	3.03	2.27	3.56	2.19	4.10	2.11	4.63
	1350	3.12	0.97	2.95	1.54	2.82	2.12	2.71	2.70	2.62	3.27	2.53	3.85	2.45	4.42	2.37	5.00
	1450	3.38	1.04	3.21	1.66	3.08	2.28	2.97	2.90	2.88	3.51	2.79	4.13	2.71	4.75	2.64	5.37
	1550	3.64	1.11	3.47	1.77	3.34	2.43	3.23	3.10	3.14	3.76	3.05	4.42	2.97	5.08	2.90	5.74
	1650	3.90	1.18	3.73	1.89	3.61	2.59	3.50	3.30	3.40	4.00	3.31	4.70	3.23	5.41	3.16	6.11
	1750	4.16	1.26	4.00	2.00	3.87	2.75	3.76	3.50	3.66	4.24	3.57	4.99	3.49	5.74	3.42	6.48
GRB65	850	4.43	1.33	4.26	2.12	4.13	2.91	4.02	3.70	3.92	4.48	3.84	5.27	3.76	6.06	3.68	6.85
	950	4.69	1.40	4.52	2.23	4.39	3.06	4.28	3.89	4.18	4.73	4.10	5.56	4.02	6.39	3.94	7.22
	1050	4.95	1.47	4.78	2.34	4.66	3.21	4.55	4.18	4.47	5.07	4.39	5.85	4.31	6.70	4.22	7.59
	1150	5.21	1.54	5.01	2.45	4.93	3.34	4.84	4.31	4.76	5.36	4.68	6.14	4.62	7.01	4.54	7.96
	1250	5.47	1.61	5.24	2.56	5.20	3.47	5.11	4.44	5.05	5.65	4.97	6.43	4.93	7.32	4.86	8.33
	1350	5.73	1.68	5.47	2.67	5.47	3.60	5.24	4.57	5.18	5.94	5.26	6.72	5.24	7.63	5.18	8.70
	1450	6.00	1.75	5.70	2.78	5.74	3.73	5.37	4.70	5.31	6.23	5.59	7.01	5.55	7.94	5.50	9.07
	1550	6.26	1.82	5.93	2.89	6.01	3.86	5.50	4.83	5.44	6.52	5.92	7.30	5.82	8.25	5.82	9.44
	1650	6.52	1.89	6.16	3.00	6.28	3.99	5.63	4.96	5.57	6.81	6.21	7.59	6.11	8.56	6.14	9.81
	1750	6.78	1.96	6.39	3.11	6.55	4.12	5.76	5.09	5.70	7.10	6.50	7.88	6.40	8.87	6.46	10.18
GRB80	800	4.11	1.30	3.83	2.09	3.62	2.87	3.44	3.65	3.28	4.44	3.13	5.22	3.00	6.00	2.87	6.78
	900	4.71	1.47	4.43	2.35	4.22	3.23	4.03	4.11	3.87	4.99	3.73	5.87	3.60	6.75	3.47	7.63
	1000	5.31	1.63	5.03	2.61	4.82	3.59	4.63	4.57	4.47	5.55	4.33	6.52	4.20	7.50	4.07	8.48
	1100	5.91	1.79	5.63	2.87	5.42	3.95	5.23	5.02	5.07	6.10	4.93	7.18	4.79	8.25	4.67	9.33



## 性能参数 Performance parameters

Qs(m<sup>3</sup>/min) Pressure(mmAq) La(kW)

型号 Type	转速 RPM	1000mmAq		2000mmAq		3000mmAq		4000mmAq		5000mmAq		6000mmAq		7000mmAq		8000mmAq	
		Qs	La	Qs	La	Qs	La	Qs	La	Qs	La	Qs	La	Qs	La	Qs	La
GRB80	1200	6.51	1.96	6.23	3.13	6.01	4.31	5.83	5.48	5.67	6.65	5.53	7.83	5.39	9.00	5.27	10.18
	1300	7.11	2.12	6.83	3.39	6.61	4.66	6.43	5.94	6.27	7.21	6.13	8.48	5.99	9.75	5.87	11.03
	1400	7.71	2.28	7.43	3.65	7.21	5.02	7.03	6.39	6.87	7.76	6.73	9.13	6.59	10.50	6.47	11.87
	1500	8.31	2.45	8.03	3.91	7.81	5.38	7.63	6.85	7.47	8.32	7.32	9.79	7.19	11.25	7.07	12.72
	1600	8.91	2.61	8.63	4.18	8.41	5.74	8.23	7.31	8.07	8.87	7.92	10.44	7.79	12.00	7.67	13.57
	1650	9.21	2.69	8.93	4.31	8.71	5.92	8.53	7.54	8.37	9.15	8.22	10.76	8.09	12.38	7.97	13.99
	1750	9.81	2.85	9.53	4.57	9.31	6.28	9.13	7.99	8.97	9.70	8.82	11.42	8.69	13.13	8.57	14.84
	1850	10.41	3.02	10.12	4.83	9.91	6.64	9.73	8.45	9.57	10.26	9.42	12.07	9.29	13.88	9.16	15.69
	1950	11.00	3.18	10.72	5.09	10.51	7.00	10.33	8.91	10.17	10.81	10.02	12.72	9.89	14.63	9.76	16.54
GRB100	800	5.78	1.98	5.39	3.07	5.09	4.17	4.84	5.26	4.62	6.36	4.42	7.46	4.24	8.55	4.07	9.65
	900	6.61	2.22	6.23	3.46	5.93	4.69	5.68	5.92	5.46	7.15	5.26	8.39	5.08	9.62	4.91	10.85
	1000	7.45	2.47	7.07	3.84	6.77	5.21	6.52	6.58	6.30	7.95	6.10	9.32	5.91	10.69	5.74	12.06
	1100	8.29	2.72	7.90	4.22	7.61	5.73	7.36	7.24	7.14	8.74	6.94	10.25	6.75	11.76	6.58	13.27
	1200	9.13	2.96	8.74	4.61	8.45	6.25	8.20	7.90	7.98	9.54	7.78	11.18	7.59	12.83	7.42	14.47
	1300	9.97	3.21	9.58	4.99	9.29	6.77	9.03	8.55	8.81	10.33	8.61	12.12	8.43	13.90	8.26	15.68
	1400	10.81	3.46	10.42	5.37	10.12	7.29	9.87	9.21	9.65	11.13	9.45	13.05	9.27	14.97	9.10	16.88
	1500	11.65	3.70	11.26	5.76	10.96	7.81	10.71	9.87	10.49	11.92	10.29	13.98	10.11	16.03	9.94	18.09
	1600	12.49	3.95	12.10	6.14	11.80	8.33	11.55	10.53	11.33	12.72	11.13	14.91	10.95	17.10	10.78	19.30
GRB125A	1650	12.91	4.07	12.52	6.33	12.22	8.60	11.97	10.86	11.75	13.12	11.55	15.38	11.37	17.64	11.20	19.90
	1750	13.74	4.32	13.36	6.72	13.06	9.12	12.81	11.51	12.59	13.91	12.39	16.31	12.21	18.71	12.04	21.10
	1850	14.58	4.57	14.20	7.10	13.90	9.64	13.65	12.17	13.43	14.71	13.23	17.24	13.04	19.78	12.87	22.31
	1950	15.42	4.81	15.03	7.49	14.74	10.16	14.49	12.83	14.27	15.50	14.07	18.17	13.88	20.84	13.71	23.52
	780	8.59	2.61	8.17	4.18	7.85	5.74	7.58	7.31	7.34	8.88	7.13	10.44	6.93	12.01	6.75	13.58
	830	9.20	2.78	8.78	4.44	8.46	6.11	8.20	7.78	7.96	9.45	7.74	11.11	7.55	12.78	7.36	14.45
	880	9.82	2.95	9.40	4.71	9.08	6.48	8.81	8.25	8.57	10.01	8.36	11.78	8.16	13.55	7.98	15.32
	930	10.43	3.11	10.01	4.98	9.69	6.85	9.42	8.72	9.19	10.58	8.97	12.45	8.78	14.32	8.59	16.19
	990	11.17	3.31	10.75	5.30	10.43	7.29	10.16	9.28	9.93	11.27	9.71	13.25	9.51	15.24	9.33	17.23
GRB125	1050	11.91	3.51	11.49	5.62	11.17	7.73	10.90	9.84	10.66	11.95	10.45	14.06	10.25	16.17	10.07	18.28
	1110	12.64	3.72	12.23	5.94	11.91	8.17	11.64	10.40	11.40	12.63	11.19	14.86	10.99	17.09	10.81	19.32
	1180	13.50	3.95	13.09	6.32	12.77	8.69	12.50	11.06	12.26	13.43	12.05	15.80	11.85	18.17	11.67	20.54
	1250	14.36	4.18	13.95	6.69	13.63	9.20	13.36	11.71	13.12	14.23	12.91	16.74	12.71	19.25	12.53	21.76
	1320	15.23	4.42	14.81	7.07	14.49	9.72	14.22	12.37	13.98	15.02	13.77	17.67	13.57	20.32	13.39	22.97
	1390	16.09	4.65	15.67	7.44	15.35	10.24	15.08	13.03	14.84	15.82	14.63	18.61	14.43	21.40	14.25	24.19
	1470	17.07	4.92	16.65	7.87	16.33	10.82	16.06	13.78	15.83	16.73	15.61	19.68	15.42	22.63	15.23	25.59
	1560	18.18	5.22	17.76	8.35	17.44	11.49	17.17	14.62	16.93	17.75	16.72	20.89	16.52	24.02	16.34	27.15
	1650	19.28	5.52	18.87	8.84	18.55	12.15	18.28	15.46	18.04	18.78	17.83	22.09	17.63	25.40	17.44	28.72
GRB125	1750	20.51	5.86	20.10	9.37	19.78	12.89	19.51	16.40	19.27	19.92	19.06	23.43	18.86	26.94	18.67	30.46
	1850	21.74	6.19	21.33	9.91	21.01	13.62	20.74	17.34	20.50	21.05	20.28	24.77	20.09	28.48	19.90	32.20
	780	12.64	3.82	12.08	6.11	11.64	8.39	11.27	10.68	10.95	12.97	10.66	15.26	10.39	17.55	10.14	19.84
	830	13.54	4.06	12.97	6.50	12.54	8.93	12.17	11.37	11.85	13.81	11.55	16.24	11.28	18.68	11.03	21.11
	880	14.44	4.30	13.87	6.89	13.44	9.47	13.07	12.05	12.75	14.64	12.45	17.22	12.18	19.80	11.93	22.39
	930	15.34	4.55	14.77	7.28	14.34	10.01	13.97	12.74	13.64	15.47	13.35	18.20	13.08	20.93	12.83	23.66
	990	16.42	4.84	15.85	7.75	15.41	10.65	15.05	13.56	14.72	16.47	14.43	19.37	14.16	22.28	13.91	25.18
	1050	17.50	5.14	16.93	8.22	16.49	11.30	16.12	14.38	15.80	17.46	15.51	20.55	15.24	23.63	14.99	26.71
	1110	18.57	5.43	18.01	8.69	17.57	11.95	17.20	15.20	16.88	18.46	16.59	21.72	16.32	24.98	16.07	28.24
1180	19.83	5.77	19.26	9.24	18.83	12.70	18.46	16.16	18.14	19.63	17.84	23.09	17.57	26.55	17.32	30.02	



## 性能参数 Performance parameters

Qs(m<sup>3</sup>/min) Pressure(mmAq) La(kW)

型号 Type	转速 RPM	1000mmAq		2000mmAq		3000mmAq		4000mmAq		5000mmAq		6000mmAq		7000mmAq		8000mmAq	
		Qs	La	Qs	La	Qs	La	Qs	La	Qs	La	Qs	La	Qs	La	Qs	La
GRB125	1250	21.09	6.11	20.52	9.78	20.09	13.45	19.72	17.12	19.39	20.79	19.10	24.46	18.83	28.13	18.58	31.80
	1320	22.35	6.46	21.78	10.33	21.34	14.21	20.98	18.08	20.65	21.96	20.36	25.83	20.09	29.70	19.84	33.58
	1390	23.61	6.80	23.04	10.88	22.60	14.96	22.23	19.04	21.91	23.12	21.62	27.20	21.35	31.28	21.10	35.36
	1470	25.04	7.19	24.48	11.51	24.04	15.82	23.67	20.14	23.35	24.45	23.06	28.76	22.79	33.08	22.53	37.39
	1560	26.66	7.63	26.09	12.21	25.66	16.79	25.29	21.37	24.97	25.95	24.67	30.53	24.40	35.10	24.15	39.68
	1650	28.28	8.07	27.71	12.91	27.27	17.76	26.91	22.60	26.58	27.44	26.29	32.29	26.02	37.13	25.77	41.97
	1750	30.08	8.56	29.51	13.70	29.07	18.83	28.70	23.97	28.38	29.11	28.09	34.24	27.82	39.38	27.57	44.52
	1850	31.87	9.05	31.30	14.48	30.87	19.91	30.50	25.34	30.18	30.77	29.88	36.20	29.61	41.63	29.36	47.06
GRB150	780	16.35	4.92	15.64	7.87	15.09	10.82	14.62	13.78	14.22	16.73	13.85	19.68	13.51	22.63	13.20	25.59
	830	17.51	5.24	16.79	8.38	16.25	11.52	15.78	14.66	15.38	17.80	15.01	20.94	14.67	24.08	14.35	27.23
	880	18.67	5.55	17.95	8.88	17.40	12.21	16.94	15.54	16.53	18.87	16.17	22.20	15.83	25.53	15.51	28.87
	930	19.83	5.87	19.11	9.39	18.56	12.91	18.10	16.43	17.69	19.95	17.33	23.47	16.99	26.99	16.67	30.51
	990	21.22	6.24	20.50	9.99	19.95	13.74	19.49	17.49	19.08	21.23	18.72	24.98	18.38	28.73	18.06	32.47
	1050	22.61	6.62	21.89	10.60	21.34	14.57	20.88	18.55	20.47	22.52	20.11	26.49	19.77	30.47	19.45	34.44
	1110	24.00	7.00	23.28	11.20	22.73	15.40	22.27	19.61	21.86	23.81	21.50	28.01	21.16	32.21	20.84	36.41
	1180	25.62	7.44	24.90	11.91	24.36	16.38	23.89	20.84	23.49	25.31	23.12	29.77	22.78	34.24	22.46	38.71
	1250	27.24	7.89	26.53	12.62	25.98	17.35	25.52	22.08	25.11	26.81	24.74	31.54	24.40	36.27	24.09	41.00
	1320	28.86	8.33	28.15	13.32	27.60	18.32	27.14	23.31	26.73	28.31	26.36	33.31	26.02	38.30	25.71	43.30
	1390	30.48	8.77	29.77	14.03	29.22	19.29	28.76	24.55	28.35	29.81	27.98	35.07	27.65	40.33	27.33	45.59
	1470	32.34	9.27	31.62	14.84	31.08	20.40	30.61	25.96	30.21	31.53	29.84	37.09	29.50	42.65	29.18	48.22
	1560	34.42	9.84	33.71	15.74	33.16	21.65	32.70	27.55	32.29	33.46	31.92	39.36	31.59	45.27	31.27	51.17
	1650	36.51	10.41	35.80	16.65	35.25	22.90	34.78	29.14	34.38	35.39	34.01	41.63	33.67	47.88	33.36	54.12
1750	38.83	11.04	38.11	17.66	37.56	24.29	37.10	30.91	36.69	37.53	36.33	44.16	35.99	50.78	35.67	57.40	
1850	41.14	11.67	40.43	18.67	39.88	25.67	39.42	32.68	39.01	39.68	38.64	46.68	38.31	53.68	37.99	60.68	
GRB200A	830	28.66	8.40	27.75	13.44	27.06	18.48	26.47	23.51	25.96	28.55	25.49	33.59	25.06	38.63	24.66	43.67
	880	30.52	8.90	29.61	14.25	28.92	19.59	28.33	24.93	27.81	30.27	27.35	35.62	26.92	40.96	26.52	46.30
	930	32.38	9.41	31.47	15.06	30.78	20.70	30.19	26.35	29.67	31.99	29.21	37.64	28.78	43.29	28.38	48.93
	990	34.61	10.02	33.70	16.03	33.01	22.04	32.42	28.05	31.90	34.06	31.44	40.07	31.01	46.08	30.61	52.09
	1050	36.84	10.62	35.93	17.00	35.24	23.37	34.65	29.75	34.13	36.12	33.67	42.50	33.24	48.87	32.84	55.25
	1110	39.07	11.23	38.16	17.97	37.47	24.71	36.88	31.45	36.36	38.19	35.90	44.92	35.47	51.66	35.07	58.40
	1180	41.67	11.94	40.76	19.10	40.07	26.27	39.48	33.43	38.96	40.59	38.50	47.76	38.07	54.92	37.67	62.08
	1250	44.27	12.65	43.37	20.24	42.67	27.82	42.08	35.41	41.57	43.00	41.10	50.59	40.67	58.18	40.27	65.77
	1320	46.87	13.36	45.97	21.37	45.27	29.38	44.69	37.40	44.17	45.41	43.70	53.42	43.27	61.44	42.87	69.45
	1390	49.48	14.06	48.57	22.50	47.87	30.94	47.29	39.38	46.77	47.82	46.30	56.26	45.87	64.70	45.47	73.13
GRB200	1470	52.45	14.87	51.54	23.80	50.85	32.72	50.26	41.65	49.74	50.57	49.28	59.49	48.85	68.42	48.45	77.34
	880	39.61	11.45	38.59	18.32	37.81	25.19	37.16	32.05	36.58	38.92	36.06	45.79	35.58	52.66	35.13	59.53
	930	42.00	12.10	40.98	19.36	40.20	26.62	39.55	33.88	38.97	41.13	38.45	48.39	37.97	55.65	37.52	62.91
	990	44.86	12.88	43.85	20.61	43.07	28.33	42.41	36.06	41.84	43.79	41.31	51.52	40.83	59.24	40.39	66.97
	1050	47.73	13.66	46.72	21.86	45.94	30.05	45.28	38.25	44.70	46.44	44.18	54.64	43.70	62.83	43.25	71.03
	1110	50.60	14.44	49.58	23.10	48.81	31.77	48.15	40.43	47.57	49.10	47.05	57.76	46.57	66.42	46.12	75.09
	1180	53.94	15.35	52.93	24.56	52.15	33.77	51.49	42.98	50.92	52.19	50.39	61.40	49.91	70.61	49.47	79.82
	1250	57.29	16.26	56.27	26.02	55.50	35.77	54.84	45.53	54.26	55.29	53.74	65.05	53.26	74.80	52.81	84.56
	1320	60.63	17.17	59.62	27.48	58.84	37.78	58.18	48.08	57.61	58.38	57.08	68.69	56.60	78.99	56.16	89.29
	1390	63.98	18.08	62.96	28.93	62.19	39.78	61.53	50.63	60.95	61.48	60.43	72.33	59.95	83.18	59.50	94.03
1470	67.80	19.12	66.79	30.60	66.01	42.07	65.35	53.55	64.78	65.02	64.25	76.49	63.77	87.97	63.33	99.44	



## 性能参数 Performance parameters

Qs(m³/min) Pressure(mmAq) La(kW)

型号 Type	转速 RPM	1000mmAq		2000mmAq		3000mmAq		4000mmAq		5000mmAq		6000mmAq		7000mmAq		8000mmAq	
		Qs	La	Qs	La	Qs	La	Qs	La	Qs	La	Qs	La	Qs	La	Qs	La
GRB250	830	50.02	14.40	48.83	23.03	47.92	31.67	47.15	40.31	46.48	48.95	45.87	57.59	45.30	66.22	44.78	74.86
	880	53.21	15.26	52.02	24.42	51.11	33.58	50.34	42.74	49.66	51.90	49.05	61.06	48.49	70.21	47.97	79.37
	930	56.39	16.13	55.20	25.81	54.29	35.49	53.53	45.17	52.85	54.85	52.24	64.52	51.68	74.20	51.15	83.88
	990	60.21	17.17	59.03	27.48	58.12	37.78	57.35	48.08	56.67	58.38	56.06	68.69	55.50	78.99	54.97	89.29
	1050	64.04	18.21	62.85	29.14	61.94	40.07	61.17	51.00	60.50	61.92	59.88	72.85	59.32	83.78	58.80	94.71
	1110	67.86	19.25	66.67	30.81	65.76	42.36	64.99	53.91	64.32	65.46	63.71	77.01	63.14	88.57	62.62	100.12
	1180	72.32	20.47	71.13	32.75	70.22	45.03	69.46	57.31	68.78	69.59	68.17	81.87	67.60	94.15	67.08	106.43
	1250	76.78	21.68	75.59	34.69	74.68	47.70	73.92	60.71	73.24	73.72	72.63	86.73	72.06	99.74	71.54	112.75
	1320	81.24	22.90	80.05	36.63	79.14	50.37	78.38	64.11	77.70	77.85	77.09	91.58	76.53	105.32	76.00	119.06
	1390	85.70	24.11	84.51	38.58	83.60	53.04	82.84	67.51	82.16	81.97	81.55	96.44	80.99	110.91	80.46	125.37
1470	90.80	25.50	89.61	40.80	88.70	56.10	87.93	71.39	87.26	86.69	86.65	101.99	86.08	117.29	85.56	132.59	
GRB300A	830	66.52	19.20	64.86	30.71	63.59	42.23	62.52	53.75	61.57	65.26	60.72	76.78	59.94	88.30	59.21	99.82
	880	70.76	20.35	69.11	32.56	67.84	44.77	66.77	56.99	65.82	69.20	64.97	81.41	64.18	93.62	63.45	105.83
	930	75.01	21.51	73.36	34.41	72.09	47.32	71.01	60.22	70.07	73.13	69.22	86.03	68.43	98.94	67.70	111.84
	990	80.11	22.90	78.45	36.63	77.18	50.37	76.11	64.11	75.17	77.85	74.31	91.58	73.53	105.32	72.80	119.06
	1050	85.21	24.28	83.55	38.85	82.28	53.42	81.21	67.99	80.27	82.56	79.41	97.13	78.63	111.70	77.90	126.27
	1110	90.30	25.67	88.65	41.07	87.38	56.48	86.31	71.88	85.36	87.28	84.51	102.68	83.72	118.09	82.99	133.49
	1180	96.25	27.29	94.60	43.66	93.32	60.04	92.25	76.41	91.31	92.79	90.46	109.16	89.67	125.53	88.94	141.91
	1250	102.20	28.91	100.54	46.25	99.27	63.60	98.20	80.95	97.26	98.29	96.40	115.64	95.62	132.98	94.89	150.33
	1320	108.15	30.53	106.49	48.84	105.22	67.16	104.15	85.48	103.20	103.79	102.35	122.11	101.57	140.43	100.84	158.75
	1390	114.09	32.15	112.44	51.43	111.17	70.72	110.09	90.01	109.15	109.30	108.30	128.59	107.51	147.88	106.78	167.16
1470	120.89	34.00	119.23	54.40	117.96	74.79	116.89	95.19	115.95	115.59	115.09	135.99	114.31	156.39	113.58	176.78	
GRB300	800	101.28	29.11	98.93	46.58	97.12	64.05	95.60	81.52	94.26	98.99	93.05	116.46	91.94	133.92	90.90	151.39
	900	114.64	32.75	112.30	52.40	110.49	72.06	108.97	91.71	107.63	111.36	106.42	131.01	105.31	150.66	104.27	170.32
	1000	128.01	36.39	125.66	58.23	123.86	80.06	122.34	101.90	121.00	123.73	119.79	145.57	118.68	167.40	117.64	189.24
	1100	141.38	40.03	139.03	64.05	137.23	88.07	135.71	112.09	134.37	136.11	133.16	160.13	132.05	184.14	131.01	208.16
	1200	154.75	43.67	152.40	69.87	150.60	96.08	149.08	122.28	147.74	148.48	146.53	174.68	145.41	200.89	144.38	227.09
	1300	168.12	47.31	165.77	75.70	163.97	104.08	162.45	132.47	161.11	160.85	159.90	189.24	158.78	217.63	157.75	246.01
	1400	181.49	50.95	179.14	81.52	177.34	112.09	175.82	142.66	174.48	173.23	173.27	203.80	172.15	234.37	171.12	264.94
	1470	194.86	54.59	192.81	88.00	185.22	120.30	183.70	150.85	180.00	178.75	178.79	217.00	175.00	250.00	174.00	290.00
GRB350	600	118.60	34.31	115.52	54.90	113.16	75.49	111.16	96.08	109.40	116.66	107.82	137.25	106.36	157.84	105.00	178.43
	700	139.61	40.03	136.53	64.05	134.16	88.07	132.17	112.09	130.41	136.11	128.82	160.13	127.36	184.14	126.00	208.16
	800	160.62	45.75	157.54	73.20	155.17	100.65	153.18	128.10	151.42	155.55	149.83	183.00	148.37	210.45	147.01	237.90
	900	181.63	51.47	178.54	82.35	176.18	113.23	174.19	144.11	172.43	174.99	170.84	205.88	169.38	236.76	168.02	267.64
	1000	202.64	57.19	199.55	91.50	197.19	125.81	195.19	160.13	193.44	194.44	191.85	228.75	190.39	263.06	189.03	297.38
	1100	223.64	62.91	220.56	100.65	218.19	138.39	216.20	176.14	214.44	213.88	212.86	251.63	211.39	289.37	210.04	327.11
	1200	244.65	68.63	241.57	109.80	239.20	150.98	237.21	192.15	235.45	233.33	233.86	274.50	232.40	315.68	231.04	356.85
	1300	265.66	74.34	262.58	118.95	260.21	163.56	258.22	208.16	256.46	252.77	254.87	297.38	253.41	341.98	252.05	386.59
1400	286.67	80.06	283.58	128.10	281.22	176.14	279.22	224.18	277.47	272.21	275.88	320.25	274.42	368.29	273.06	416.33	
GRB400	600	137.87	39.77	134.46	63.63	131.84	87.50	129.64	111.36	127.69	135.22	125.94	159.09	124.32	182.95	122.82	206.81
	700	162.22	46.40	158.81	74.24	156.19	102.08	153.99	129.92	152.04	157.76	150.29	185.60	148.67	213.44	147.17	241.28
	800	186.57	53.03	183.16	84.85	180.54	116.66	178.34	148.48	176.39	180.30	174.64	212.11	173.02	243.93	171.52	275.75
	900	210.92	59.66	207.51	95.45	204.89	131.25	202.69	167.04	200.74	202.83	198.99	238.63	197.37	274.42	195.87	310.22
	1000	235.27	66.29	231.86	106.06	229.24	145.83	227.04	185.60	225.09	225.37	223.34	265.14	221.72	304.92	220.22	344.69
	1100	259.62	72.91	256.21	116.66	253.59	160.41	251.39	204.16	249.44	247.91	247.69	291.66	246.07	335.41	244.57	379.16
	1200	283.97	79.54	280.56	127.27	277.94	174.99	275.74	222.72	273.79	270.45	272.04	318.17	270.42	365.90	268.92	413.62





## 外形尺寸图 (配用卧式出口消音器) Installation dimensions (horizontal outlet silencer)

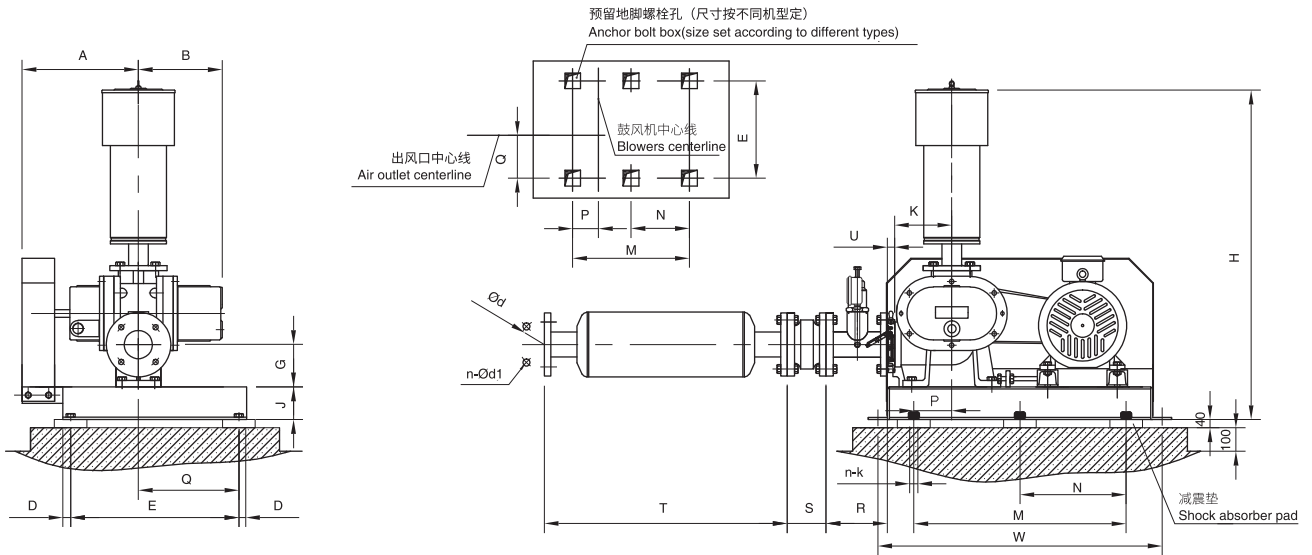

型号 Type	A	B	D	E	G	H	J	K	M	N	W	P	Q	R	S	T	U	Ød	n-Ød1	地脚螺栓 n-k
GRB40	235	230	20	350	104	741	56	140	520	-	-	98	95	150	95	595	18	110	4-Ø18	4-M12x160
GRB50	320	270	20	412	103.5	921	80	140	520	-	700	93	211	150	105	595	18	125	4-Ø18	4-M12x160
GRB65	342.5	300	20	412	104	924	80	152	520	-	700	93	188.5	150	115	595	18	145	4-Ø18	4-M12x160
GRB80	383	304	20	482	106.5	1241	80	180	700	-	900	112.5	238	180	135	795	22	160	8-Ø18	4-M12x160
GRB100	426	354	20	482	110	1245	80	180	700	-	900	130.5	195	180	150	795	22	180	8-Ø18	4-M12x160
GRB125A	495	375.5	24	602	135	1840	100	250	950	-	1150	178	291	250	165	1260	22	210	8-Ø18	4-M16x220
GRB125	495	435.5	24	602	157.5	1835	100	262	950	-	1150	182	271	250	165	1260	22	210	8-Ø18	4-M16x220
GRB150	574	490.5	24	602	163	1860	100	250	950	-	1150	182	212	250	180	1260	22	240	8-Ø23	4-M16x220
GRB200A	534	472	30	790	198	2285	160	358	1300	650	-	313	441	250	210	1645	25	295	8-Ø23	6-M20x350
GRB200	584	522	30	790	194	2285	160	345	1300	650	-	310	391	250	210	1645	25	295	8-Ø23	6-M20x350
GRB250	695	597	30	940	216	2520	160	356	1400	700	-	270	490	250	230	1750	38	350	12-Ø23	6-M20x350
GRB300A	880	697	30	940	255	2660	160	360	1500	750	-	248	470	350	250	1850	38	400	12-Ø23	6-M20x350
GRB300	795	627.5	35	1030	300	2955	250	510	2000	1000	-	321	487	350	250	1850	38	400	12-Ø23	6-M20x350

注：当GRB-40配电机功率在1.1~4kW及以上，GRB-150配电机功率在55kW及以上，GRB-200配电机功率在90kW及以上，风机底座尺寸另询。  
Note: When the motor power of GRB-40 is 1.1~4kW or above, GRB-150 is 55kW or above, and GRB-200 is 90kW or above, the size of the blower base should be specifically confirmed.

## 地脚螺栓 Anchor bolt

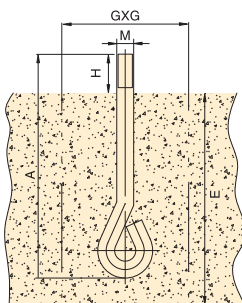

地脚螺栓 M Anchor bolt GB799-88	A	H	E	GxG	适用型号 Application type
M10	160	32	224	100x100	GRB32
M12	160	36	224	100x100	GRB40,50,65,80,100
M16	220	45	275	120x120	GRB125(A),150
M20	300	55	345	150x150	GRB200(A),250,300(A)
M30	400	72	428	200x200	GRB350,400

注：1. 图注E为最小尺寸，根据安装的土壤情况，应当加深。  
2. GxG为二次浇灌前的预留孔尺寸。  
Note: 1. The note E on the drawing is the minimum size, it shall be deepened properly according to the soil condition in the installation place.  
2. GxG is the size of the preformed holes for the secondary casting.



## 外形尺寸图 (配用立式出口消音器) Installation dimensions (vertical outlet silencer)

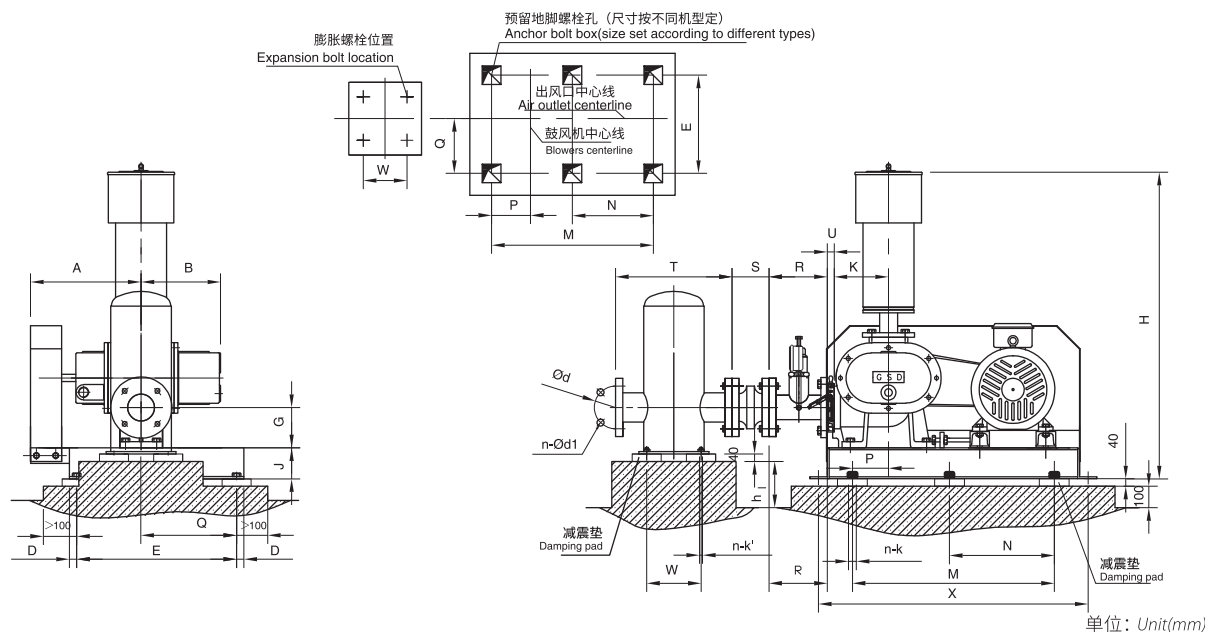

单位: Unit(mm)

型号 Type	A	B	D	E	G	H	h	J	K	M	N	X	P	Q	R	S	T	U	W	Ød	n-Ød1	地脚螺栓 n-k	地脚螺栓 n-k'
GRB40	235	230	20	350	104	741	100	56	140	500	-	700	98	95	150	95	300	18	140	110	4-Ø18	4-M12x160	4-M12x150
GRB50	320	270	20	412	103.5	921	123.5	80	140	520	-	700	93	211	150	105	300	18	140	125	4-Ø18	4-M12x160	4-M12x150
GRB65	342.5	300	20	412	104	924	114	80	152	520	-	700	93	188.5	150	115	350	18	170	145	4-Ø18	4-M12x160	4-M12x150
GRB80	383	304	20	482	106.5	1241	101.5	80	180	700	-	900	112.5	238	180	135	400	22	190	160	8-Ø18	4-M12x160	4-M12x150
GRB100	426	354	20	482	110	1245	95	80	180	700	-	900	130.5	195	180	150	450	22	240	180	8-Ø18	4-M12x160	4-M12x150
GRB125A	495	375.5	24	602	135	1840	105	100	250	950	-	1150	178	291	250	165	500	22	240	210	8-Ø18	4-M16x220	4-M12x150
GRB125	515	435.5	24	602	157.5	1835	127.5	100	262	950	-	1150	182	271	250	165	500	22	240	210	8-Ø18	4-M16x220	4-M12x150
GRB150	574	490.5	24	602	163	1860	113	100	250	950	-	1150	182	212	250	180	600	22	290	240	8-Ø23	4-M16x220	4-M12x150
GRB200A	534	472	30	790	198	2285	162	160	358	1300	650	-	313	441	250	210	650	25	350	295	8-Ø23	6-M20x350	4-M12x150
GRB200	584	522	30	790	194	2285	158	160	345	1300	650	-	310	391	250	210	650	25	350	295	8-Ø23	6-M20x350	4-M12x150

注: 当GRB-40配电机功率在1.1~4kW及以上, GRB-150配电机功率在55kW及以上, GRB-200配电机功率在90kW及以上, 风机底座尺寸另询。  
Note: When the motor power of GRB-40 is 1.1-4kW or above, GRB-150 is 55kW or above, and GRB-200 is 90kW or above, the size of the blower base should be specifically confirmed.

## 泄压阀 Relief valve

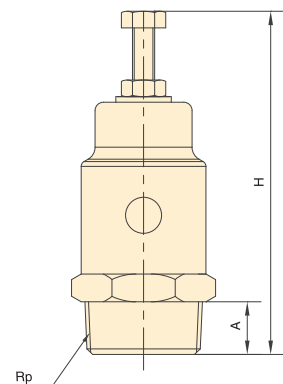

单位: Unit(mm)

型号 Type	A	H	适用机型 Application type	重量 Weight (kg)
SV 1/2"	15	91.5	GRB32	0.3
SV1 1/4"	19	145	GRB40,50,65,80	0.3
SV2"	24	185	GRB100,125(A),150	1
SV3"	30	230	GRB200(A),250	1.6
SV100	90	490	GRB300(A)	29
SV150	95	490	GRB350,400	38.4

注: SV100、SV150为法兰连接, 参考JB/T 1.0MPa法兰标准。  
Note: Type SV100/SV150 is connect with flange. Refer to JB/T 1.0MPa.



## 入口消音器 Suction silencer

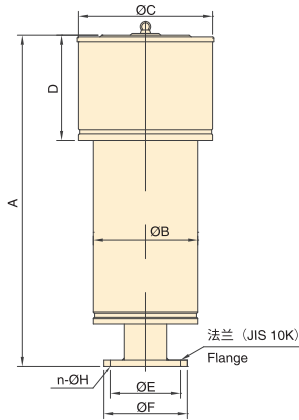

单位: Unit(mm)

型号 Type	A	B	C	D	E	F	n-ØH	重量 Weight (kg)	适用型号 Application type
SS32	113	-	105	-	-	-	-	4	GRB32
SS40	400	133	150	220	105	140	4-Ø14	7	GRB40
SS50	550	133	150	220	120	155	4-Ø19	10	GRB50
SS65	550	159	190	280	140	175	4-Ø19	12	GRB65
SS80	820	219	245	280	150	185	8-Ø19	21	GRB80
SS100	820	245	273	330	175	210	8-Ø19	27	GRB100
SS125	1310	273	310	350	210	250	8-Ø23	45	GRB125(A)
SS150	1310	299	340	370	240	280	8-Ø23	52	GRB150
SS200	1500	330	380	370	290	330	12-Ø23	81	GRB200(A)
SS250	1700	400	480	550	355	400	12-Ø25	98	GRB250
SS300	1825	500	600	650	400	445	16-Ø25	135	GRB300(A)
SS350	2237	550	676	700	445	490	16-Ø25	200	GRB350
SS400	2533	600	720	750	510	560	16-Ø27	250	GRB400

注: SS32为1"Rp连接方式  
Note: Type SS32 is connect with Rp thread standard 1".

## 卧式出口消音器 Horizontal outlet silencer

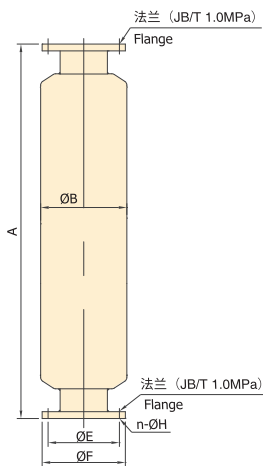

单位: Unit(mm)

型号 Type	A	B	E	F	n-ØH	重量 Weight (kg)	适用型号 Application type
DS50	595	159	125	160	4-Ø18	12	GRB50
DS65	595	159	145	180	4-Ø18	13.5	GRB65
DS80	795	219	160	195	8-Ø18	24	GRB80
DS100	795	219	180	215	8-Ø18	25	GRB100
DS125	1260	290	210	245	8-Ø18	48	GRB125(A)
DS150	1260	290	240	280	8-Ø23	51	GRB150
DS200	1645	356	295	335	8-Ø23	79	GRB200(A)
DS250	1750	405	350	390	12-Ø23	98	GRB250
DS300	1850	484	400	440	12-Ø23	140	GRB300(A)
DS350	2500	560	460	500	16-Ø23	280	GRB350
DS400	2700	610	515	565	16-Ø26	340	GRB400

## 立式出口消音器 Vertical outlet silencer

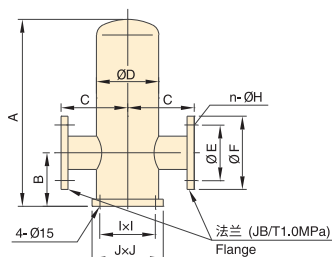

单位: Unit(mm)

型号 Type	A	B	C	D	E	F	n-ØH	I	J	重量 Weight (kg)	适用型号 Application type
VDS50	420	120	150	162	125	160	4-Ø18	140	180	19.0	GRB50
VDS65	480	130	175	185	145	180	4-Ø18	170	210	27.0	GRB65
VDS80	595	145	200	225	160	195	8-Ø18	190	235	36.9	GRB80
VDS100	660	155	225	285	180	215	8-Ø18	240	310	51.8	GRB100
VDS125	840	190	250	281	210	245	8-Ø18	240	310	65.9	GRB125(A) GRB125
VDS150	990	210	300	346	240	280	8-Ø23	290	376	99.6	GRB150
VDS200	1040	256	325	410	295	335	8-Ø23	350	425	131.5	GRB200(A) GRB200



## 三通管 "T" -joint

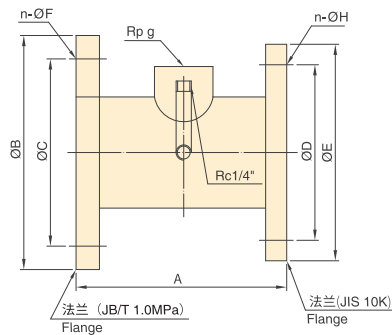

单位: Unit(mm)

型号 Type	A	B	C	n-ØF	D	E	n-ØH	g	重量 Weight (kg)	适用型号 Application type
HJ40	150	145	110	4-Ø18	120	155	4-Ø19	1 1/4"	5.5	GRB40
HJ50	150	160	125	4-Ø18	120	155	4-Ø19	1 1/4"	5.8	GRB50
HJ65	150	180	145	4-Ø18	140	175	4-Ø19	1 1/4"	7.5	GRB65
HJ80	180	195	160	8-Ø18	150	185	8-Ø19	1 1/4"	9	GRB80
HJ100	180	215	180	8-Ø18	175	210	8-Ø19	2"	11.5	GRB100
HJ125	250	245	210	8-Ø18	210	250	8-Ø23	2"	15.5	GRB125(A)
HJ150	250	280	240	8-Ø23	240	280	8-Ø23	2"	18	GRB150
HJ200	250	335	295	8-Ø23	290	330	12-Ø23	3"	23	GRB200(A)
HJ250	250	390	350	12-Ø23	355	400	12-Ø25	3"	30	GRB250
HJ300	350	440	400	12-Ø23	400	445	16-Ø25	DN100	45	GRB300(A)
HJ350	400	500	460	16-Ø23	445	490	16-Ø25	DN150	59	GRB350
HJ400	400	565	515	16-Ø26	510	560	16-Ø27	DN150	72	GRB400

注: DN100、150为法兰连接, 参考JB/T 1.0MPa规范尺寸。  
Note: Type DN100\150 is connect with flange. Refer to JB/T 1.0MPa.

## 弹性接头 Flexible connector

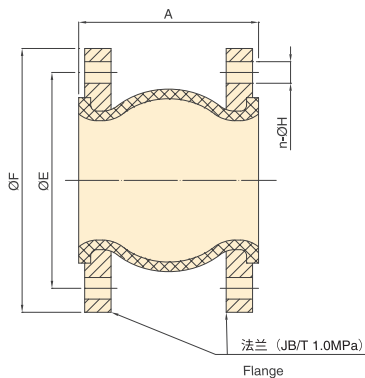

单位: Unit(mm)

型号 Type	A	E	F	n-ØH	重量 Weight (kg)	适用型号 Application type
KXT50	105	125	160	4-Ø18	3.72	GRB50
KXT65	115	145	180	4-Ø18	4.68	GRB65
KXT80	135	160	195	8-Ø18	5.5	GRB80
KXT100	150	180	215	8-Ø18	6.7	GRB100
KXT125	165	210	245	8-Ø18	8.3	GRB125(A)
KXT150	180	240	280	8-Ø23	12	GRB150
KXT200	210	295	335	8-Ø23	14	GRB200(A)
KXT250	230	350	390	12-Ø23	18.6	GRB250
KXT300	250	400	440	12-Ø23	27.5	GRB300(A)
KXT350	255	460	500	16-Ø23	34	GRB350
KXT400	255	515	565	16-Ø26	47	GRB400

## 逆止阀 Check valve

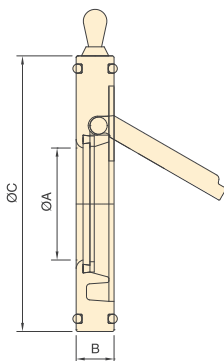

单位: Unit(mm)

型号 Type	A	B	C	重量 Weight (kg)	适用型号 Application type
DCV-50	37	18	105	1	GRB40, GRB50
DCV-65	45	18	125	1.4	GRB65
DCV-80	52	22	140	0.8	GRB80
DCV-100	65	22	160	0.9	GRB100
DCV-125	90	22	190	1.2	GRB125(A)
DCV-150	115	22	215	1.5	GRB150
DCV-200	160	25	270	2.6	GRB200(A)
DCV-250	180	38	325	12.5	GRB250
DCV-300	213	38	375	18.5	GRB300(A)
DCV-350	246	38	435	23.5	GRB350
DCV-400	278	42	487	32	GRB400



如蒙洽询请指示下列各项：  
For further details, please fulfill the chart below.

客户：  
Customer \_\_\_\_\_

承办人员：  
Undertaker \_\_\_\_\_

工程名称：  
Name of project \_\_\_\_\_

工程地点：  
Address of project \_\_\_\_\_

电话：  
Telephone \_\_\_\_\_

传真：  
Fax \_\_\_\_\_

* 用途 Usage	<input type="checkbox"/> 压缩用 Compression		<input type="checkbox"/> 真空用 Vacuum	
* 当地状况 Local condition	海拔m Elevation		最高相对湿度% Max relative humidity	
	当地大气压力(MPa) Local atmospheric pressure		最高气温(°C) Max air temperature	
* 气体性质 Gas character	名称 Name		温度(°C) Temperature	
	成份 Constituents		各组分比例 Ratio of constituent	
风机参数 Blower's parameter	* 风量(m <sup>3</sup> /min) Capacity		口径(mm) Diameter	
	* 风压(mmAq) Pressure		转速(r/min) Speed	
电机参数 Motor's parameter	型式 Type		电压(V) Voltage	
	功率(kW) Power		频率(Hz) Frequency	
	极数 Pole		其它 Others	
安装位置 Location	<input type="checkbox"/> 室内安装 Indoor install	<input type="checkbox"/> 遮雨棚式室外安装 Camping outdoor install	<input type="checkbox"/> 其它 Others_____	
* 传动方式 Driving mode	<input type="checkbox"/> 皮带传动(标准型) Belt-driven(Standard)		<input type="checkbox"/> 直联传动 Direct drive	
其它要求 Other requirement				

备注：1. 以上资料请尽可能完整填写。

2. 项目前加注“\*”者，请务必填写。

Notes: 1. Please fill in the parameter lists as complete as possible.

2. The item with “\*” must be filled.



## 用途说明 Applications

水处理  
Water treatment

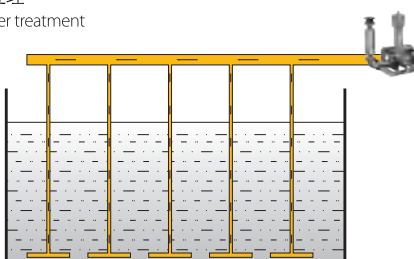

**1** 用于污水处理厂的曝气处理  
Aeration of sewage

燃烧炉  
Incinerator

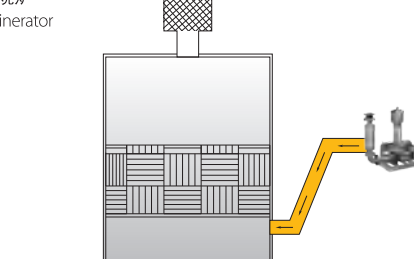

**5** 用于助燃，增加氧气促进燃烧  
Used for combustion, increasing oxygen to promote combustion

啤酒厂、饮料行业  
Brewery and beverage industry

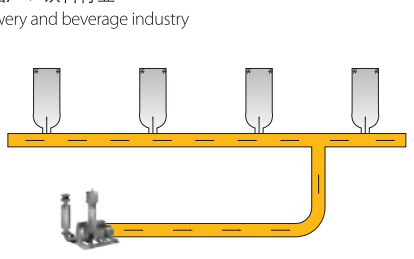

**2** 通过气体运动将瓶内死角清理干净  
Clean up the bottle's dead angle by gas

水处理  
Water treatment

啤酒厂、饮料行业  
Brewery and beverage industry

喷涂  
Spray finishing

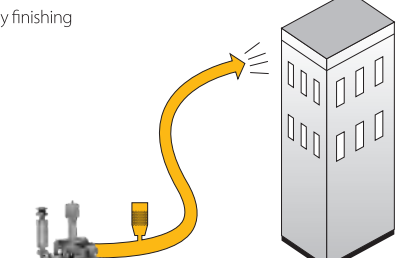

**3** 通过气体将防火材料喷涂到墙上或钢筋结构上  
Use gas spraying fire-resistant material on the wall

喷涂  
Spray finishing

养殖场  
Fishery

养殖场  
Fishery

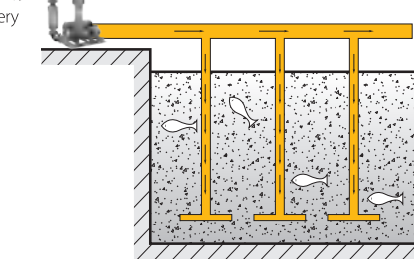

**4** 养殖场中增加水中氧气  
Increasing oxygen in water

发酵厂  
Fermenting plant

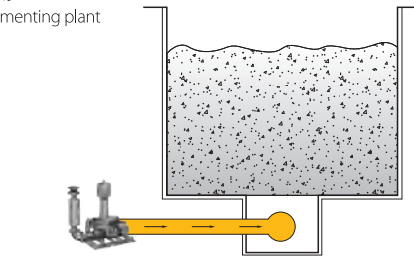

**6** 通过增加含氧量，来促进发酵  
Increasing oxygen to promote the fermentation





洗车  
Car washing

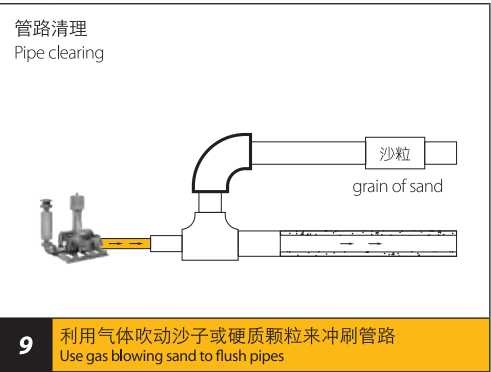
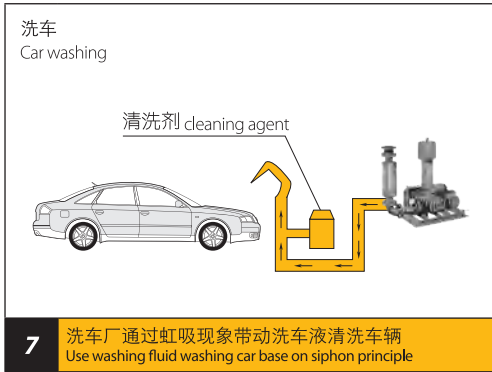

管路清理  
Pipe clearing

电镀行业  
Electroplate factory

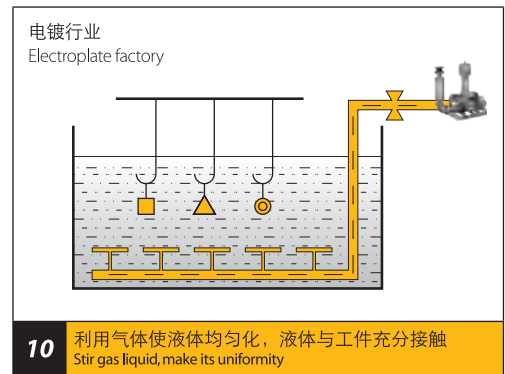

桑拿  
Sauna

物料输送  
Conveying

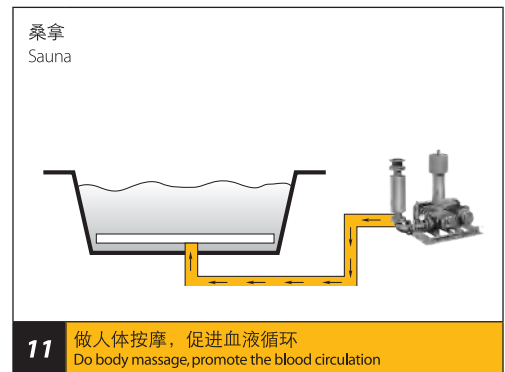

造纸厂  
Paper mill

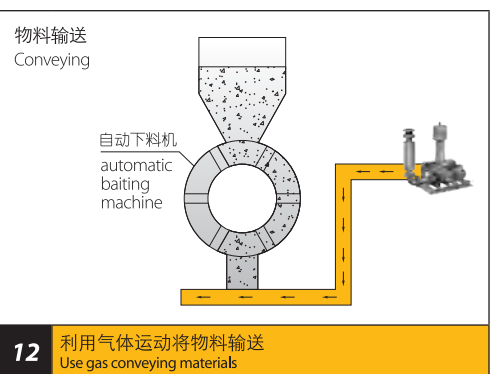
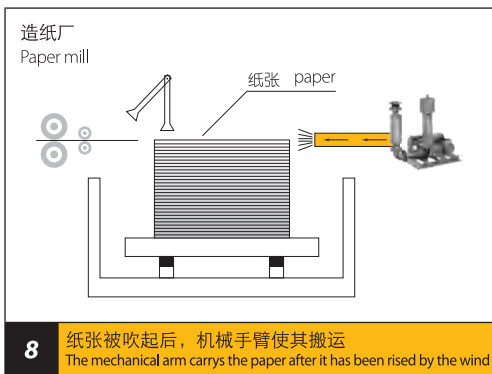

欢迎索取以下产品型录



### 泵系列

潜水泵系列 | 陆上泵系列 | 特种泵系列



### 搅拌推流系列

搅拌机系列 | 推流器系列



### 供氧曝气系列

曝气机系列 | 曝气盘系列 | 曝气管系列



### 风机系列

磁悬浮鼓风机 | 空气悬浮鼓风机 | 三叶罗茨鼓风机系列



### 污泥处理设备

带式脱水机 | 厢式压滤机 | 叠螺式脱水机 | 污泥干化设备 | 浅层高效气浮设备



### 智能化系列

智能设备 | 水务设备健康管理 | 水务系统工艺优化智联管理



### 反应器及套装设备

芬顿反应系统 | MBR生物膜反应器 | 预制泵站 | 一体化污水处理设备



### 耗材药剂及相关设备

生物绳 | PAC 聚合氯化铝 | PAM 聚丙烯酰胺 | 泡药设备

## GSD 的经营理念

G-Green 绿色 S-Safe 安全 D-Development 永续经营



川源

## 水处理系统专业合作伙伴

免费咨询电话

400-657-9066

数据来源：公司实验室数据及客户实际使用数据，具体使用环境不同，数据可能存在差异。

The data on the brochure is based on the laboratory testing data and customers' actual operation data in the past. The actual data may be different in different application conditions.

本型录内容如有变更，恕不另行通知。

We reserve the right to change content without notice.

川源（中国）机械有限公司版权所有 all rights reserved. CY-34

